

说明书递交文档

设计 DESIGN	蒋高敏 2016. 9. 13	图纸名称 PART NAME Belling BCF300 (CE-BD295-ST) 说明书				图号/物料编码 PART NO.	
校对 CO. BY	周军					1613	
标准化 STANDARD						材料 MATERIAL 双胶纸	
业务 seller	许岩	图样标记 REL	版本号 REV. NO.	重量(g) WEIGHT	比例 scale		
批准 AUTHORIZE			0		1:1		
		共 页 TOTAL SHEETS		第 页 NO. OF SHEETS		美的冰箱事业部 MIDEA REFRIGERATION DIVISION	

技术要求

1. 尺寸：32K；
2. 说明书印刷颜色：单色；
3. 样板需送设计部门封样；
4. 制件必须满足QMB-J53.005 产品说明书及其它类似印刷件技术规范。
5. 需要符合美的冰箱事业的最新版《QMB-GC08.007 有害物质管理规定》的限值要求。

标记 MARKER	变更内容	修改日期	签名
①			
②			
③			
④			
⑤			



Instruction Manual

Chest Freezer

MODEL: BCF300



Contents

Safety Warnings	4
Unpacking	6
Location	7
Free Space Requirements.....	7
Installing the Door Handle.....	7
Cleaning Before Use	7
Before Using Your Unit.....	7
Product Overview	8
Operation	9
Switching On Your Unit	9
Adjusting the Temperature.....	9
Fast Freezing.....	9
Noises Inside the Unit!.....	10
Tips for Keeping Food in the Unit.....	10
Preparations for Freezing.....	10
Defrosting Frozen Food.....	10
Cleaning	11
Defrosting	11
Cleaning the Interior and the Exterior of the Unit.....	11
Maintenance	12
Care When Handling / Moving the Unit.....	12
Servicing.....	12
Switching Off for Long Periods of Time.....	12
Disposal	12
Troubleshooting	13
Power Cut	13
The Freezer is Particularly Cold	13
The Freezer is Particularly Warm	13
The Freezer is Not Working	13
Condensation Appears on the Outside of the Freezer	13

Safety Warnings

For your continued safety and to reduce the risk of injury or electric shock, please follow all the safety precautions listed below.

- Read all instructions carefully before using the unit and keep them for future reference.
- Retain the manual. If you pass the unit onto a third party, make sure to include this manual.
- This appliance is intended for indoor household use and similar applications such as:
 - farm houses and by clients in hotels, motels and other residential type environment;
 - bed and breakfast type environment;
 - catering and similar non-retail applications.
- Ensure that the plug is easily accessible to enable disconnection from the mains supply.
- If the mains cable is damaged, it must be replaced by the manufacturer, its service agent or a qualified technician in order to avoid a hazard.
- Choose a location for your unit away from heat sources such as radiators or fires as refrigerant and vesicant are burnable.
- The unit must be maneuvered by a minimum of 2 persons.
- This appliance can be used by children aged from 8 years and above and persons with reduced physical, sensory or mental capabilities or lack of experience and knowledge if they have been given supervision or instruction concerning use of the appliance in a safe way and understand the hazards involved. Children shall not play with the appliance. Cleaning and user maintenance shall not be made by children without supervision.
- Children should be supervised to ensure that they do not play with the unit.
- If your unit is fitted with a lock to prevent children being trapped inside, keep the key out of reach and not in the vicinity of the unit.
- Do not store explosive substances such as aerosol cans with a flammable propellant in this appliance.

- Do not store bottles or glass containers in the freezer compartment. Contents can expand when frozen (fizzy drinks) which may break the bottle and damage your freezer compartment. (If applicable)



WARNING

- Keep ventilation openings in the unit enclosure or in the built-in structure clear of obstructions.
- Do not use mechanical devices or other means to accelerate the defrosting process, other than those recommended by the manufacturer.
- Do not use electrical appliances inside the food storage compartments of the unit, unless they are of the type recommended by the manufacturer.
- Do not damage the refrigerant circuit (The refrigerant is a very environmental-friendly gas but is also combustible. Take care when transporting or moving the unit to ensure that the refrigeration circuit is not damaged. In the event of damage avoid naked flames or ignition sources and ventilate the room in which the unit is placed for a few minutes.)

WARNING



IT IS HAZARDOUS FOR ANYONE OTHER THAN AUTHORISED SERVICE PERSONNEL TO CARRY OUT SERVICING OF REPAIRS WHICH INVOLVE THE REMOVAL OF COVERS.



TO AVOID THE RISK OF AN ELECTRICAL SHOCK DO NOT ATTEMPT REPAIRS YOURSELF.

Thank you

for purchasing your new Belling Chest Freezer.

We recommend that you spend some time reading this instruction manual in order that you fully understand all the operational features it offers.

Read all the safety instructions carefully before use and keep this instruction manual for future reference.

Unpacking

Remove all items from the packaging. Retain the packaging. If you dispose of it please do so according to local regulations.

The following items are included:

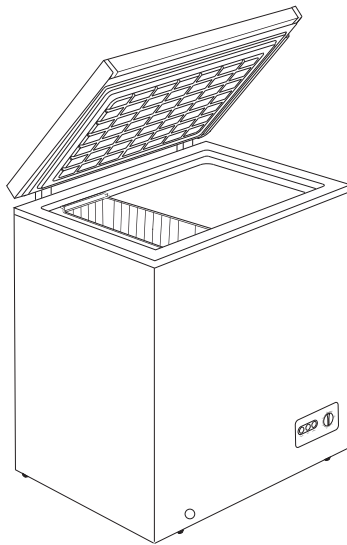

Main Unit

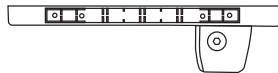

Door Handle x1



Handle Cover x1



Keys x2

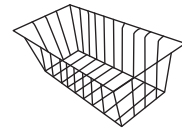

Freezer Basket x1

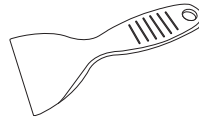

Plastic Scraper

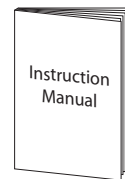

Instruction Manual

INSTALLATION

Location

When selecting a position for your unit you should make sure the floor is flat and firm and the room is well ventilated. This unit can be used in a garage or outbuilding. For optimum energy efficiency the unit should be located within an average room temperature of between 10°C and 43°C. If the room temperature drops below or rises above these temperatures the energy consumption and performance may be affected. Avoid locating your unit near a heat source, e.g. cooker, boiler or radiator. Also avoid direct sunlight as it may increase the electrical consumption. Do not drape the unit with any covering.

Free Space Requirements

When installing the unit, ensure that 25 mm of free space is left at both sides and 50 mm at the rear of the unit. Please ensure there is adequate space for the door to fully open.

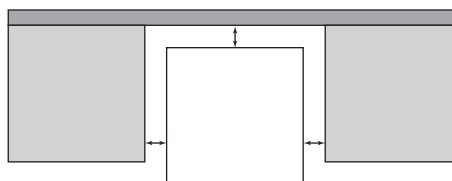

Installing the Door Handle

1. Collect the door handle, door lock, screws and handle cover from inside the unit.

2. Place and screw the door handle.

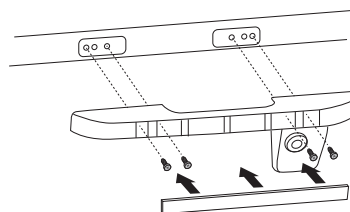

3. Place the handle cover to cover the screws, bending it slightly and fixing it flat onto the door handle.



- Make sure the door is always kept locked when not in use to prevent children from playing with the unit.
- The door lock is specially designed to prevent the keys from being left inside the lock.
- The door keys should be kept out of reach of children.

Cleaning Before Use

Wipe the inside of the unit with a weak solution of bicarbonate soda. Then rinse with warm water using a sponge or cloth. Wipe completely dry before. Clean the exterior of the unit with a damp cloth.

If you require more information refer to the **Cleaning** section.



- **Before Plugging in YOU MUST**
Check that you have a socket which is compatible with the plug supplied with the unit.
- **Before Turning On!**
Do not turn on until two hours after moving the unit. The coolant fluid needs time to settle.

Before Using Your Unit

Before placing any food in your unit, turn it on and wait for 24 hours, to make sure it is working properly and to allow it time to fall to the correct temperature. Your unit should not be overfilled.

Product Overview

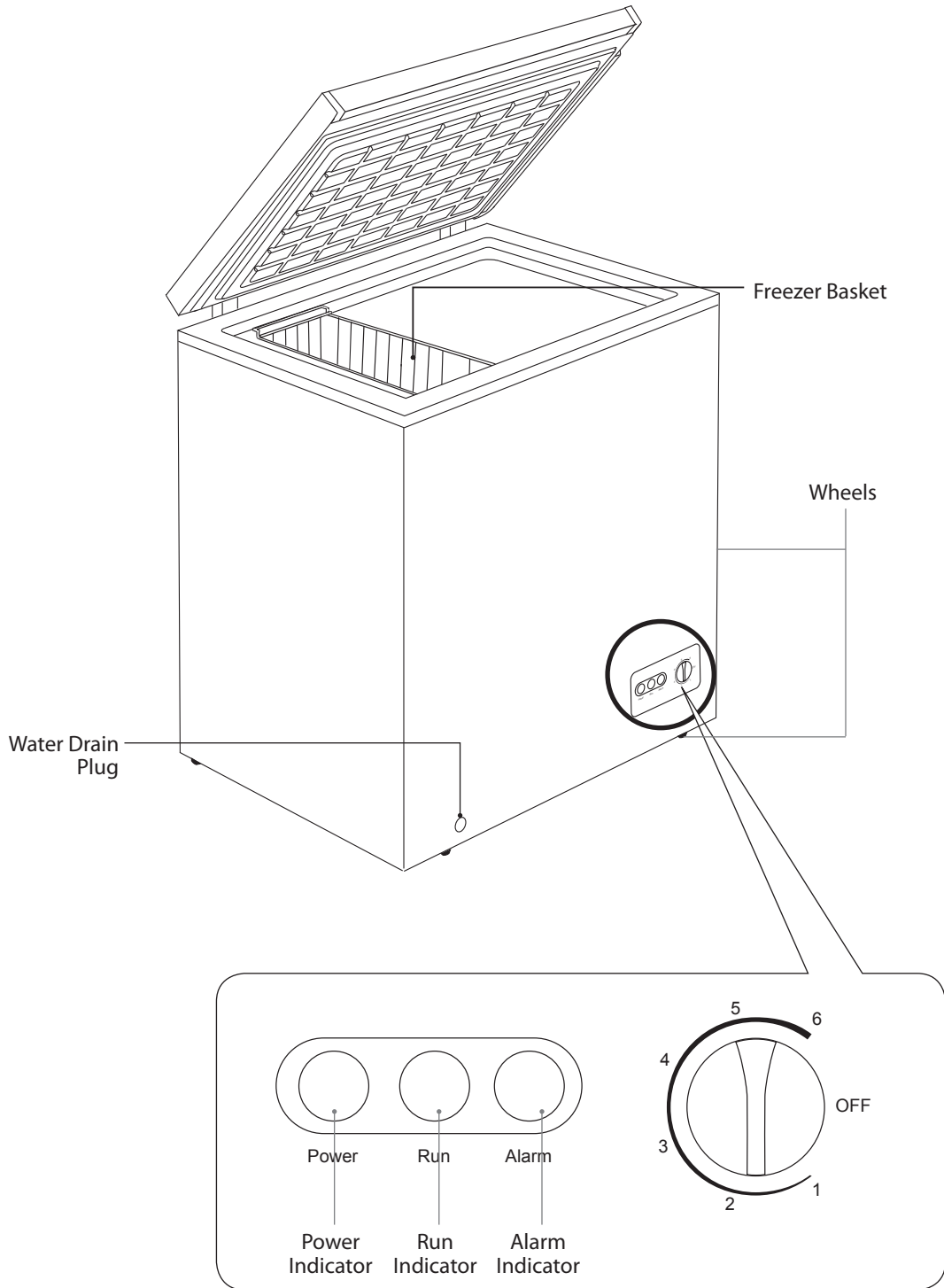

Operation

Switching On Your Unit

1. On first connecting the mains cable to the mains socket, all 3 status indicators will light up. Once the unit reaches the correct temperature:
 - Power Indicator (green) : stays on
 - Run Indicator (red) : switches on and off as the unit maintains its internal temperature
 - Alarm Indicator (amber) : lights up when the unit's internal temperature rises above -9°C .
2. The internal temperature of your freezer is controlled by a thermostat. Adjust the thermostat control dial to the desired position, **6** makes the appliance colder and is used for fast freezing. The ideal position is **4** but should be adjusted according to its environment. The appliance may not operate correctly if it is in a particularly hot or cold room or if the door is opened often or for prolonged periods.
3. The unit may not operate at the correct temperature if it is in a particularly hot or a particularly cold room, or if you open the door often.
4. To ensure that the unit is cool enough to sufficiently chill and freeze your food, wait 24 hours before filling it with food.
5. If you are concerned that your unit is not being kept cold enough and wish to check the temperature, you will need a special fridge/freezer thermometer. These are available from most supermarkets and hardware shops. Place the thermometer in the freezer and leave overnight. The correct temperature for the freezer should be -18°C or lower.

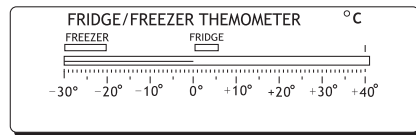
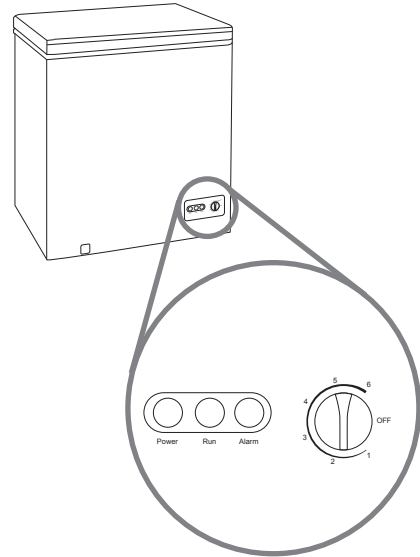

Adjusting the Temperature

The internal temperature of the unit is controlled by a thermostat. The recommended position is between **2** and **3** for colder working environments (i.e. during winter) and between **4** and **5** for hotter environments. Please adjust according to the environment.

Fast Freezing

Fresh food should be frozen as quickly as possible. Turn the dial to **6** so your freezer will operate at the coldest temperature (approximately -28°C) continuously. It helps to quickly freeze and retain more of the goodness of your food. Freezing will be completed after 24 hours. Then turn the dial back to its original position.



The Alarm indicator will light up if the unit's internal temperature rises above -9°C .

Noises Inside the Unit!

You may notice that your unit makes some unusual noises. Most of these are perfectly normal, but you should be aware of them!

These noises are caused by the circulation of the refrigerant liquid in the cooling system. It has become more pronounced since the introduction of CFC free gases. This is not a fault and will not affect the performance of your unit. This is the compressor motor working, as it pumps the refrigerant around the system.

Tips for Keeping Food in the Unit

- Cooked meats/fishes should always be stored above raw meats/fishes to avoid bacterial transfer. Keep raw meats/fishes in a container which is large enough to collect juices and cover it properly. Place the container at the bottom inside the unit.
- Leave space around your food, to allow air to circulate inside the unit. Ensure all parts of the unit are kept cool.
- To prevent transfer of flavours and drying out, pack or cover the food separately. Fruit and vegetables do not need to be wrapped.
- Always let pre-cooked food cool down before you put in the unit. This will help to maintain the internal temperature of the unit.
- To prevent cold air escaping from the unit, try to limit the number of times you open the door. We recommend that you only open the door when you need to put food in or take food out.

Preparations for Freezing

- Use quality food and handle it as little as possible. Freeze food in small quantities as it freezes faster, takes less time to defrost and enables you to control the quantity you need better.
- Leave cooked food to cool completely. Chill food before freezing if possible.
- Consider how you will want to cook the food before freezing it.
- Don't freeze food in metal containers if you may want to microwave it straight from the freezer.
- Use special freezer bags, freezer film, polythene bags, plastic containers, and aluminium foil (heavy duty grade only). If in doubt, double wrap your food. Don't use aluminium foil for acidic foods, e.g. citrus fruits. Don't use thin cling film, glass, or used food containers without cleaning.
- Exclude as much air from the container as possible. You could buy a special vacuum pump which sucks excessive air out of the packaging.
- Leave a small amount of air space when freezing liquids to allow expansion.
- You can use the space in the freezer most efficiently if you freeze liquids (or solids with liquids, e.g. stew) in square blocks. This is known as "Preforming". Pour the liquid into a polythene bag which is inside a square sided container. Freeze it, and then remove it from the container and seal the bag.
- Label your frozen foods as they will look the same when in frozen state. Use special tapes, labels and pens with different colours. This allows you to easily organise and to effectively use the freezer. Write the contents and date; otherwise the frozen food might exceed the storage time and this could cause food poisoning. Please refer to your food packaging for the recommended storage time.

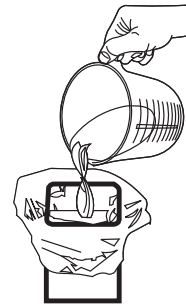

Defrosting Frozen Food

1. Take the frozen food out and let it defrost at room temperature. Don't forget that defrosting in a warm area encourages the growth of bacteria and low temperature cooking may not destroy dangerous bacteria.
2. Drain off and throw away any liquid lost during defrosting.
3. Always make sure there are no ice-crystals in the food before cooking, particularly with meat. These crystals indicate that the food has not fully defrosted.
4. Cook food as soon as possible after defrosting.
5. Many microwaves and ovens have a defrost setting. To avoid bacterial build up, only use these if you intend to cook the food immediately afterwards.

Cleaning

Defrosting

Frost may build up in the freezer compartment after it has been used for a period of time. Scrape away the frost using a plastic scraper (included).



Do not use a metal or sharp instrument to scrape away the frost, nor should you use any electrical appliances to aid defrosting.

We recommend that defrosting should be carried out when the frost layer builds up to 10 mm. Choose a time when the stock of frozen food is low, follow these procedures:

1. Take out the food, turn the unit off at the mains supply, unplug the unit and leave the door open. Ideally, the frozen food should be put into another freezer. If this is not possible, wrap the food in several sheets of newspaper or large towels and then a thick rug or blanket to keep it cool.
2. To remove melted frost from the drain hole, place a suitable container under it. Remove the drain cap on the front of the unit. Reach down into the freezer and unscrew the drain plug.
3. Scrape away the frost using the plastic scraper. Defrosting the remaining frost can be sped up by placing a bowl of hot water inside the freezer compartment and closing the door. As the solid frost loosens, scrape it away with the plastic scraper and remove.
4. After all the water has drained away, replace the drain plug and then the drain cap.
5. When defrosting is complete, clean your unit's interior and exterior.
6. When the compartment is completely clean and dry, close the door, switch on the freezer again and turn the thermostat control dial to **6**.
7. Leave the unit to cool down for an hour, and then you can start placing frozen food inside the unit. Remember to turn the thermostat control dial to **4** after 4 hours.

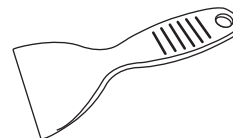

Cleaning the Interior and the Exterior of the Unit

- Wipe the inside of the unit with a weak solution of bicarbonate soda and then rinse with warm water using a sponge or cloth. Wipe completely dry.
- Use a damp cloth to clean the exterior, and then wipe with a standard furniture polish. Make sure that the door is closed to avoid the polish getting on the magnetic door seal or inside the unit.

Maintenance

Care When Handling / Moving the Unit

Hold the unit around its sides or base when moving it. Under no circumstances should it be lifted by holding the edges of the top surface.

Servicing

The unit should be serviced by an authorised engineer and only genuine spare parts should be used. Under no circumstances should you attempt to repair the unit yourself. Repairs carried out by inexperienced persons may cause injury or serious malfunction. Contact a qualified technician.

Switching Off for Long Periods of Time

When the unit is not in use for a long period of time, disconnect it from the mains supply, empty all food and clean the unit, leaving the door ajar to prevent unpleasant smells.

Disposal

Old units still have some residual value. An environmentally friendly method of disposal will ensure that valuable raw materials can be recovered and used again. The refrigerant used in the unit and insulation materials require special disposal procedures. Ensure that none of the pipes on the back of the unit are damaged prior to disposal.

Up to date information concerning options of disposing of your old unit and packaging from the new one can be obtained from your local council office.

When disposing of an old unit break off any old locks or latches and remove the doors as a safeguard.

Troubleshooting

Power Cut

If you have a freezer thermometer, place it in the freezer where you can get easy access to it to read when the power returns. If the internal temperature is -9°C or less when the power returns, your food is safe. The food in your freezer will remain frozen for approximately 40 hours with the door closed. If you know the power is going to be cut, 40 hours prior to the power cut, turn the thermostat control dial to **6**, this will make the freezer colder than normal. If there is no warning, turn the thermostat control dial to **6** after the power cut. Don't open the door more than necessary.

The Freezer is Particularly Cold

You may have accidentally left the thermostat control dial on **6**.

The Freezer is Particularly Warm

The compressor may not be working. Turn the thermostat control dial to **6**. If there is no humming noise, it is not working. Contact your local service agent where you purchased your freezer.

The Freezer is Not Working

Check if the **Power** indicator is illuminated. If not, check if the unit is plugged in and switched on. Check that the fuse in the plug has not blown. Plug in another appliance, such as a lamp, to see if the socket is working.

Condensation Appears on the Outside of the Freezer

Condensation may appear on the surface of the Chest Freezer, this is normal - wipe dry with a dry cloth.

This may be due to a change in the room temperature. Wipe off any residue of moisture. If the problem continues contact the local store where you purchased your freezer.

When your appliance is working, the condenser at the back (exposed models) may become hot or alternatively the sides may become hot (hidden condenser models).

BELLING CUSTOMER CARE

In case of difficulty within the Republic of Ireland, please call Belling Customer Care Centre Helpline on:

Phone 01 8428222

Fax 01 8428091

When you dial this number you will hear a recorded message and be given a number of options.

This indicates that your call has been accepted and is being held in a queue. Calls are answered in strict rotation as our Customer Care Representatives become available.

Enter appliance numbers here for future reference:

Model No
<input type="text"/> <input type="text"/> <input type="text"/> <input type="text"/> <input type="text"/> <input type="text"/> <input type="text"/> <input type="text"/>
Serial No
<input type="text"/> <input type="text"/> <input type="text"/> <input type="text"/> <input type="text"/> <input type="text"/> <input type="text"/> <input type="text"/>

Please ensure you have the above details (Model No and Serial No) to hand when calling Belling Customer Care. They are essential to booking your call.

Service email: service@dimpco.ie

Spares email: spares@dimpco.ie

Website for consumables: www.dimpco.ie

Hours of business: 9am - 1pm & 2pm - 5pm Monday - Friday

